



The Signal

February 2006

Volume 2

Of Special Interest:

- Dave Rollino Field Hand
- Next Club Meeting on Wednesday, March 29th at the Bridgewater Library at 8:00pm in Room B.



Contents:

Treasurer's Report	1
Dave Rollino Design	2
Building Tip	3
50-50 Results	4
Upcoming Events	4

The meeting was held on February 22nd and called to order at 8:02pm. The meeting adjourned at 9:15pm.

Attendance: Tony Rossi, Jim Vigani, Len Cacciatore, Jim Beard, Marc Julius, Dave Shields, Patrick Aanstoots, Joe Melick, Dan Edelman, Greg Clarke, Rich Negran, Len Ferenczak, Ray Jajko, Dave Rollino, Ken Hoeg, Lyn Alford, Bill Becker, Sal LoSardo, Cash McManus.

The club was happy to welcome our guests Alvaro Guerrero and Michael Kountouris.

And we're very happy to welcome our newest member: Chris DeBlass.



RC Club Building Class

I just wanted to report that Jim Vigani's scratch building class is going very well. We have met several times since we began and we all have pieces of a wing (or an entire wing!) to show for our hard work. At this rate, we should all have a finished plane to fly by the beginning of the season.

The class has been very informative and I think I can safely speak for everyone involved when I say "Thank You Jim" for all of your time and effort. We've all learned a lot already and look forward to learning even more. We can't wait to bring them in for show-n-tell!



Treasurer's Report

Expenses

Shirts, Jim Vigani, Ck #1523	\$ 406.00
Flyer of The Year Plaque and Frequency Pins (Less dues for Len C/Tommy & 2 Shirts) Ck #1522	\$ 45.25

	\$ 451.25

Income

January 50-50	\$ 19.00
Dues/Shirts	\$ 564.50

	\$ 583.50

Balance As Of 2/22/2006 \$1,602.49

Udvar-Hazy Trip Set for Saturday, March 18th

The club is going to take a bus trip down to Washington DC and visit the Udvar-Hazy center, a branch of the Smithsonian Museum.

The bus will be leaving from the Vo-Tech parking lot (across the street from the library) **promptly at 7am**. Be there early because the bus cannot and will not wait. It's a 4 hour ride and we need to leave on time. The trip is \$25 per person. The club voted that if we can't fill all the seats, an additional \$10 per person would not be a problem.

If you intend to join us, or know someone who would like to, you should be sure to contact Len Cacciatore as soon as possible.





If you have any items that you would like listed in the For Sale section of the newsletter, forward them to the newsletter editor. Items will be listed for a three (3) month period. After three months they will be deleted from the newsletter. If you would like your ad to run longer you must make your request again.

Nothing for sale this month! (You gotta sell stuff to make room for new stuff!)

Dave Rollino Designed Field Hand...

Dave Rollino has continued to amaze the club with his PVC creations.

This month he brought in the Field Hand. It's an amazing carrier made of PVC that when flipped over at the field becomes a work stand.

Dave – these are amazing! This rivaled anything we saw at the WRAM show. Maybe you should start a business!



Tony's ME-109



Tony brought in his Simple Series ME-109 for show-n-tell. It's quite the airplane with a Norvel engine as a power plant.

Tony did a great job finishing this beauty and we can't wait to see if fly around the field this Spring.

Thanks for sharing it with us Tony!



Builder's Corner

Holes for Wing Dowels

A standard scenario for installing holding dowels in the leading edge of the wing - put the wing in place on the fuselage, mark the wing through the pre drilled holes in the fuselage former, remove the wing and drill it for the dowels. The problem is, when you drill, the drill bit "wanders" slightly, and the alignment comes out slightly off.

Solution? Use a piece of brass tubing as a hole saw. Cut teeth in one end, glue into a piece of hardwood to act as a handle. Now you can actually do or at least start the hole with the wing in place. Pushing and twisting the tubing, you cut right through balsa, and even lite ply with little effort. Put in a small piece of dowel in your first hole so that the alignment stays accurate for the second hole.

Note: a longer piece of brass tubing, with teeth on the end, can cut nice holes in the aft fuselage for nyrod exits.

Accurate Wing Dowel Holes

-Tools by K & S !!!

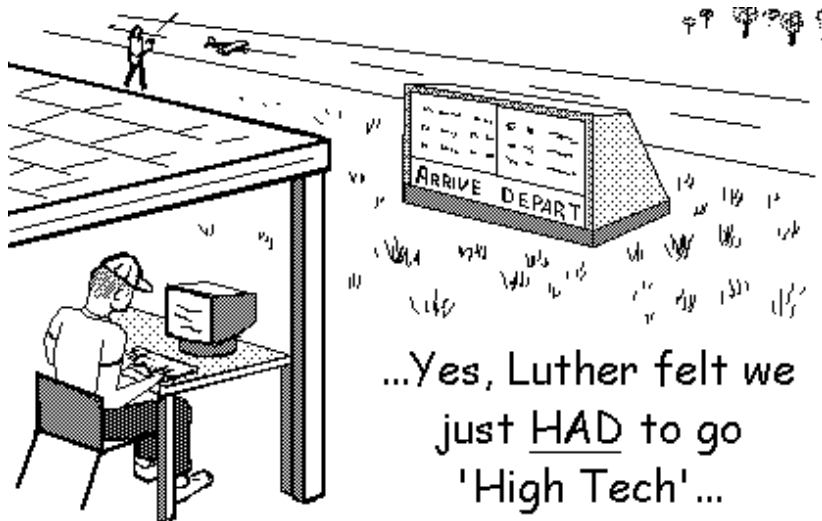
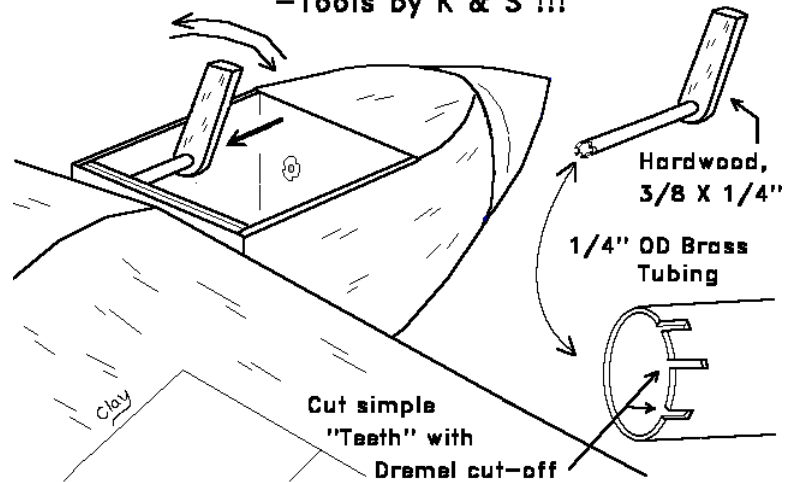

A Suggestion for the new runway at our field!



Somerset Signal Senders



A great resource
for everything
RC...

Somerset Signal
Senders, Inc.
Copyright, 2006 ©

Miscellaneous Club Business

February 50-50: The club took in \$46. First place (\$13) was won by Jim Vigani and 2nd place (\$10) was won by ????.

The new shirts are in. If you placed an order and have not yet received/paid for your shirt(s), please contact Jim Vigani.

Sal LoSardo brought in a home made thrust meter and gave a demonstration. It's a wonder of ingenuity and we appreciate your sharing it with us!

Jim Vigani brought in his Airfoilyz Yak 54 that is being sold on Paul Gentile's website. Someone even created a download for it for Aerofly Professional! Very nice Jim!

Bill Becker gave a demonstration of a home made balancing bar that can be used on large airplanes for both side to side balancing, as well as front to back balancing. Quite clever Bill.

Several members attended the WRAM show and all reported that they had a good time. Several members said it felt "smaller" than previous years and there were definitely less vendors present.

But the breakout sessions were good and there were some great bargains to be had. Club friend, Paul Gentile, had a booth for his new Jim Vigani designed foamies and they were selling very well. Check out Paul's website: 3dxhobbies.com. Club members receive a discount on any purchase.

Meeting with Park Commissioner: Tony, Ray and Rich met with Karren Newman, the Park Commissioner on February 17th. Karren is very pleased with our club and all that we do for the County and down at the field. You can all take pride in that, as it is a reflection of all of us.

We all need to be more vigilant down at the field for people without the proper credentials. It's a matter of safety and protecting our flying field.

Many improvements were discussed and Tony will be following up with Karren to see when they will be done.

One of the highlights is the pending removal of the plane eating tree on the left side!

Club Information

- The Somerset Signal Senders will meet Wednesday, March 29th at 8pm at the Bridgewater Library in Meeting Room B.
- Our club website is <http://www.somersetsignalsenders.org>
- Questions concerning our website can be directed to: webmaster@somersetsignalsenders.org
- Head Flight Instructor: Tony Rossi
- Field Safety Officer: Len Cacciatore
- Newsletter Editor: Marc Julius, newsletter@somersetsignalsenders.org
- Questions can be directed to: President@somersetsignalsenders.org

Upcoming Events

March 11, 2006
Lebanon Swap Meet

March 18, 2006
Udvar-Hazy Club Trip