



# The Signal

November 2005

Volume 1

## Of Special Interest:

- New Pin Board Unveiled
- Next Club Meeting on Wednesday, December 14th at the Bridgewater Library at 8:00pm in Room B.



## Contents:

Treasurer's Report	1
For Sale	2
Udvar-Hazy Anyone?	3
50-50 Winner	4
Upcoming Events	4

The meeting was held on November 28<sup>th</sup> and called to order at 8:00pm. The meeting adjourned at 8:50pm.

**Attendance:** Tony Rossi, Jim Vigani, Len Cacciatore, Jim Beard, Marc Julius, Dave Shields, Joe Lachowski, Rich Negran, Len Ferenchak, Ray Jajko, Joe Melick, Dave Rollino, Greg Clarke, Tom Jederlinic, Dan Edelman, Lyn Alford, Cash McManus, Marc Vigod, Ken Hoeg and Tom Viechor.

The club was happy to welcome our guest Frank Vitelli.



At this meeting, nominations from the floor for Member-At-Large and any of the Officer positions were accepted. Ray Jajko was nominated for the position of Member-At-Large and was uncontested. No one was nominated from the floor for any of the officer positions.

The club purchased two flight books to supplement the flight instructors. One Week To Solo and Advanced Aerobatic Flight Training.



## Treasurer's Report

### Expenses

None	\$ 0.00
	-----
	\$ 0.00

### Income

October 50-50	\$ 19.00
Dues	\$ 20.00
1 <sup>st</sup> Place 50-50 Donated Back by Marc J.	\$ 12.00
2 <sup>nd</sup> Place 50-50 Donated Back by Tony R.	\$ 7.00
T-Shirts (1 @ \$12.00)	\$ 12.00
	-----
	\$ 70.00

<b>Balance As Of 11/28/2005</b>	<b>\$1,182.33</b>
---------------------------------	-------------------

## Annual Holiday Party



The club's annual holiday party will be held on FRIDAY, JANUARY 6<sup>th</sup> at 7pm at Pizza and Pasta in Manville at 930 South Main Street.

**Payment should be made to Len Cacciatore by December 14<sup>th</sup> as we have to guarantee a minimum turnout.**

**Mail payment to: 250 Hyde Park Road, Somerset, NJ 08873. Checks made payable to Len.**

The menu will consist of a selection of appetizers, three entrees, salad, soda and coffee. They have a liquor license, so you're welcome to open your own bar tabs. The club will be providing a cake for dessert. The cost per person is \$25 including tax and tip.





If you have any items that you would like listed in the For Sale section of the newsletter, forward them to the newsletter editor. Items will be listed for a three (3) month period. After three months they will be deleted from the newsletter. If you would like your ad to run longer you must make your request again.

Greg Baron has many planes, engines and accessories still available from the hangar of his dad, the late, Stu Baron. He would really like to see this stuff go to other RC enthusiasts, rather than collect dust on his shelves.

You can contact him directly at (973) 686-0924 or e-mail him at: [gbaron@hntb.com](mailto:gbaron@hntb.com)



## New Pin Board Unveiled

We all knew what a great carpenter Len Ferenchak was from the incredible job he did on our transmitter impound stand. But when Len unveiled the new pin board earlier this month, the word 'incredible' no longer fit.

Len surpassed himself with his latest creation. The new pin board is a wonderful design and he did an excellent job in its construction.

Flyers will now leave their park permits when they take a pin, eliminating the need to check if a flyer has the proper credentials.

The club voted to buy the frequency pins embossed with the AMA logo and these will be the finishing touch on a fantastic addition to our flying field.

Great job Len and a heartfelt 'Thanks' from your fellow flyers.



Len Ferenchak stands next to the newly installed pin board.



## Trip to National Air and Space Museum: Steven F. Udvar-Hazy Center

A trip to the Udvar-Hazy Center near Washington Dulles International Airport was discussed and enthusiastically received. The club is planning on taking a one day bus trip from Bridgewater to the museum on March 18<sup>th</sup>. Final details will be announced once the plans are finalized. If you are interested in going, please contact Len Cacciatore and tell him how many people you will be bringing.



The museum houses such items as the SR-71 Blackbird, the Space Shuttle Enterprise and the Boeing B-29 Superfortress Enola Gay to name but a few.

You can check out the details of the museum on the internet at this address: <http://www.nasm.si.edu/museum/udvarhazy/>

## Need Vertical Storage?

(Reprinted from AMA Website with Permission)

If you have the need for vertical storage, then take a look at this cheap-and-easy vertical rack made from 3/4-inch PCV pipe, PCV fittings (Ts, 90-degree elbows, and end caps if desired). Elastic fabric or bungee cords for securing the aircraft and foam rubber for cushioning.

It will store your fuselage and wing conveniently while cutting down on hangar rash. It will also keep the front engine bearing lubricated.

\*No measurements are included because size and shape will vary.

\*Glue is toxic and flammable. Use in a well ventilated area.

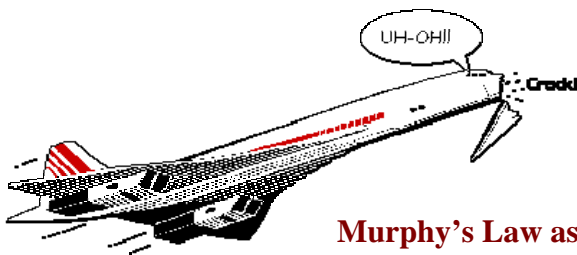
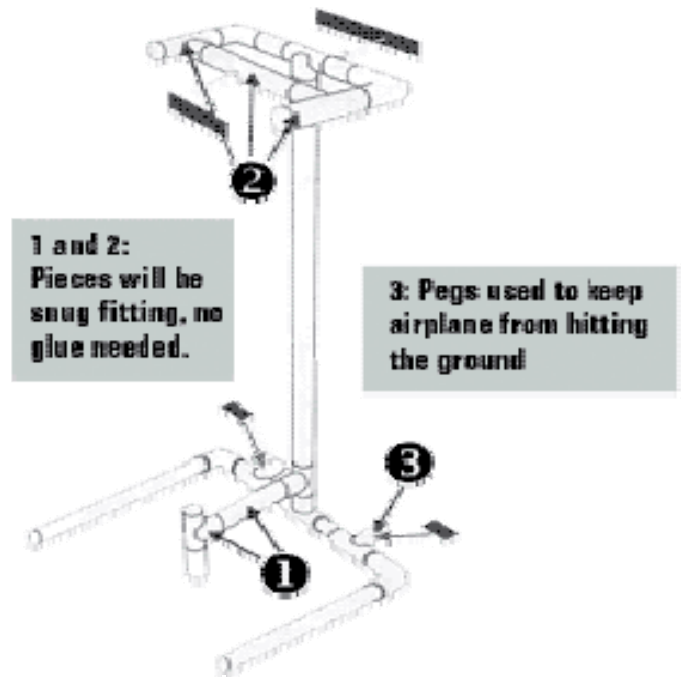

## Murphy's Law as it applies to Model Aircrafts

- If something can break, it will.
- Gravity takes no prisoners.
- Trees are ALWAYS closer than they appear.
- To calculate the location of the exact rear center underneath your workbench, just drop a small screw.
- The velocity of the wind is inversely proportional to the size of your airplane.
- A new glow plug will last forever if you have spares, but only about thirty minutes if you don't.
- If you can't go flying tomorrow, the weather will be perfect.



## Somerset Signal Senders



A great resource  
for everything  
RC...

Somerset Signal  
Senders, Inc.  
Copyright, 2005 ©

## Miscellaneous Club Business

**November 50-50:** The club took in \$26. First place (\$16) was won by Greg Clarke and he donated his winnings to the club. Thanks Greg!

Second place (\$10) was won by Dan Edelman. Congratulations Dan!

The weekend of March 11<sup>th</sup> is the Lebanon Swap Meet. Several members have expressed interest in going, so we may caravan out there. Keep the date open, it should be fun!

**Polo Shirts:** Jim Vigani has begun taking orders for the new polo shirts. The shirts will have the same logo that is on the front of the club T-Shirts, except these will be embroidered.

Contact Jim for orders or questions regarding prices, styles and available sizes.

**Test Team:** Jim Vigani and Paul Gentile are looking for a few experienced builders to help them test their newly designed foam kits. Jim estimates approximately 5 hours of build time necessary

to complete one of these. If you're willing to help them out, you'll receive the airframe for free and you'll be eligible to purchase the electronics and motor at cost.

You'll have to build the plane, fly it and provide feedback to Jim and Paul.

If you're interested in participating, please contact Jim Vigani or Paul Gentile.

## Club Information

- The Somerset Signal Senders will meet Wednesday, December 14th at 8pm at the Bridgewater Library in Meeting Room B.
- Our club website is <http://www.somersetsignalsenders.org>
- Questions concerning our website can be directed to: [webmaster@somersetsignalsenders.org](mailto:webmaster@somersetsignalsenders.org)
- Head Flight Instructor: Tony Rossi
- Field Safety Officer: Len Cacciatore
- Newsletter Editor: Marc Julius, [newsletter@somersetsignalsenders.org](mailto:newsletter@somersetsignalsenders.org)
- Questions can be directed to: [President@somersetsignalsenders.org](mailto:President@somersetsignalsenders.org)

## Upcoming Club Events

**December 14, 2005**

Club elections are held.

**January 6, 2006**

Club Holiday Party at Pizza & Pasta!

**February 24, 25 and 26, 2006**

WRAM Show

